

Parker-Knoll's Book of Comfort. 1970





A head rest that's high enough and soft enough.

Padded wings - curved and angled to supplement head support.

Arms, padded and placed to help you relax in the most natural position.

The right angle for your back.

Springs with the right variations in tension and spacing. For ideal lumbar support.

Rubber latex cushions: not too hard, not too soft.

Height of seat and degree of slope calculated to help you sit down and get up without any strain.

Resilient front edge to ease any pressure behind your knees.

'T' shaped cushion gives you plenty of freedom to move.

Braided tension springs (beneath seat) positioned and tensioned to hold you properly.

The science of sitting comfortably.

Turning out a chair that's perfectly comfortable is a far more difficult job than you might imagine.

Too many modern chairs for example look comfortable enough until you've sat in them for an hour or two.

Then their faults become painfully obvious. And in the long run, they only end up doing you more harm than good.

Fortunately though, we're determined to do things properly.

No chair leaves us until we're sure it covers all the finer points of comfort.

Take the Penshurst chair opposite.

Right down to the last detail, it shows how concerned we are about putting you in the right position.

The angle of the back, the height of the seat, the placing of the arms, the shape of the cushions, and the tension in the springs - they've all got to be exactly right, otherwise you'll be sitting wrongly.

And there are enough aches and pains around already through bad posture, without us adding to them.

Parker-Knoll: no one is more concerned about your comfort.

PK 1020 Strone gives you deeply satisfying 3-stage comfort at a modest outlay, and takes up surprisingly little space.



Upright.



Half recline.



Full recline.

PK 1021 Stratton. An exciting new rocker with a difference. The upholstery and the arms rock, but the base stays basic!



The rocker that doesn't look like a rocker.



PK 720 Penshurst Chair and PK 745 Hawkhurst 2-seater Settee. These exceptionally popular models combine the beauty of a strong traditional influence with contemporary comfort. The Hawkhurst settee is also available as a 3-seater. Model PK 1013.

PK 976 Bosworth chair and PK 977 Bosworth stool. The design reflects the mid-18th century but the comfort is strictly of today. As an optional partner to the chair, the matching stool makes an excellent extra seat or can turn the Bosworth into a chaise-longue.

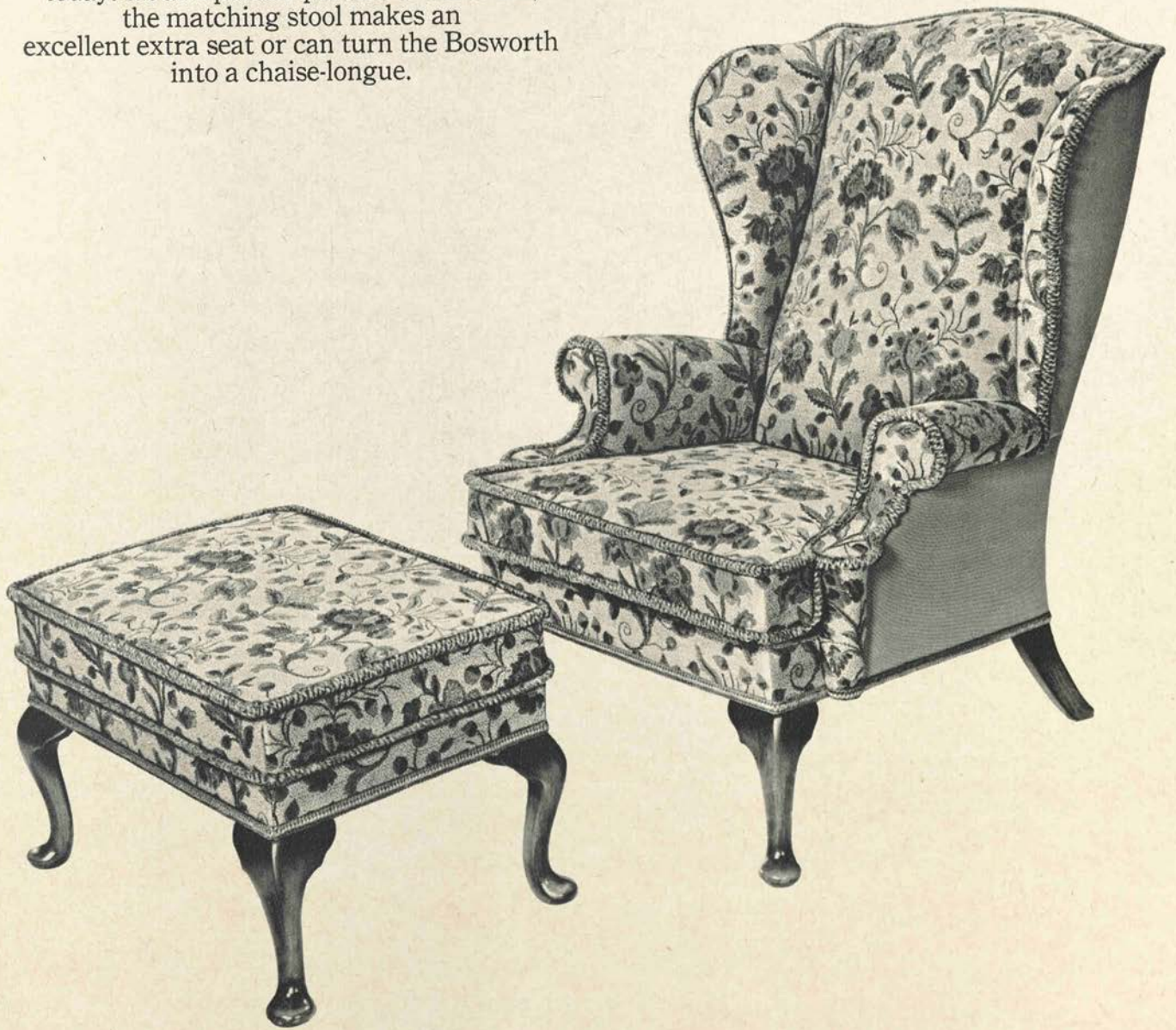

PK 757 Wingfield (left). A more contemporary version of the winged chair. Notice the graceful lines and generous upholstery.

PK 733 Langford (right). A sturdy occasional chair - ideal for hotels, clubs and restaurants.

The Froxfield group (far right) packs a lot of comfort into a small sitting room. This attractive trio consists of the Froxfield armchair (PK 749) and settee (PK 1014), and a winged version of the chair - the Frith (PK 750).

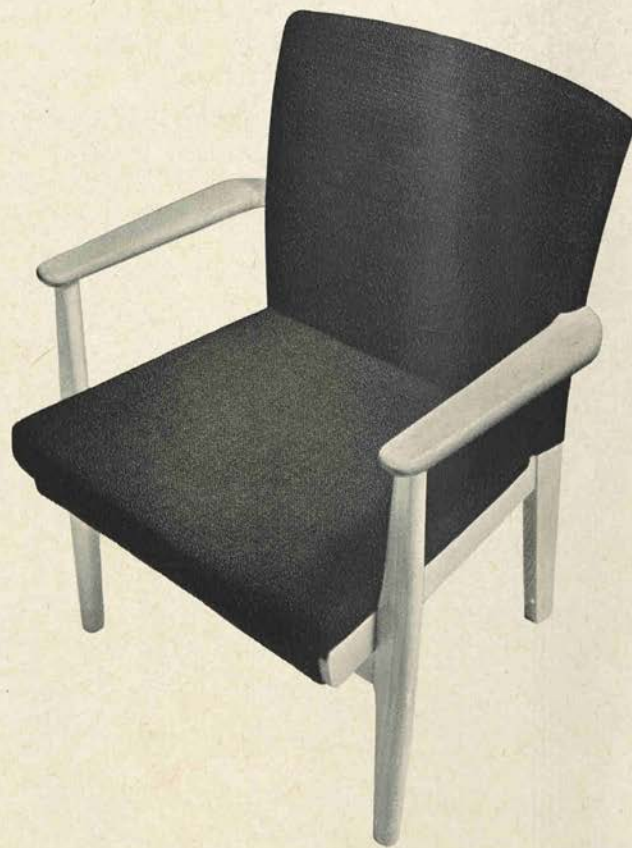
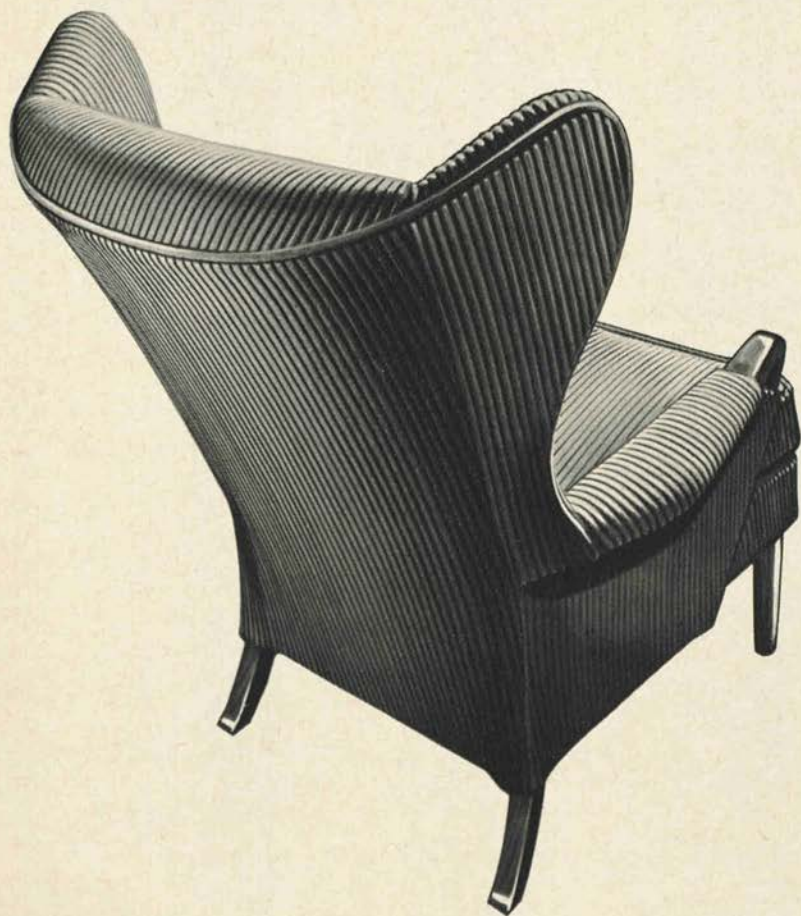





PK 1006 Novara recliner

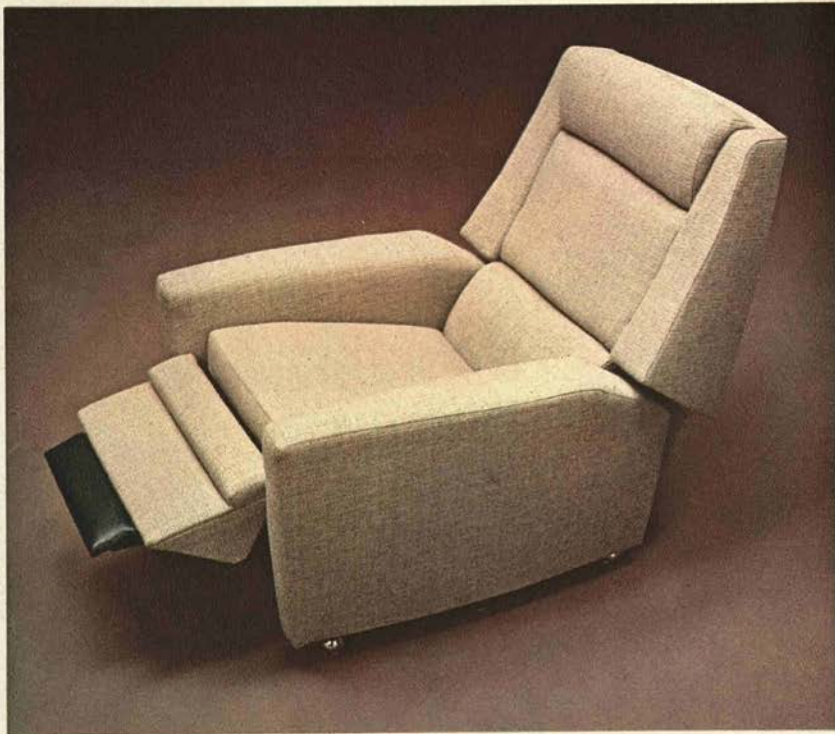
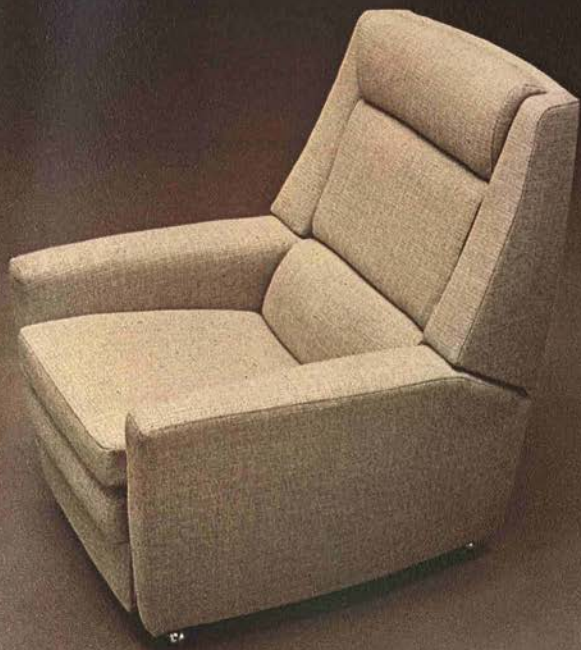

Our Novara recliner; so versatile we've devoted two pages to showing you all its stages of comfort. You can sit up, sit back, or give in completely and lounge. All the cushions (the ones you sit on and the ones you lean on) are made to our special standard; separately graded to give you just the right amount of softness and support.

The Novara rests on smooth rotating castors, so it moves at the lightest touch. Choose to cover your Novara recliner in any of our wide choice of fabrics, and then sit back and enjoy it.

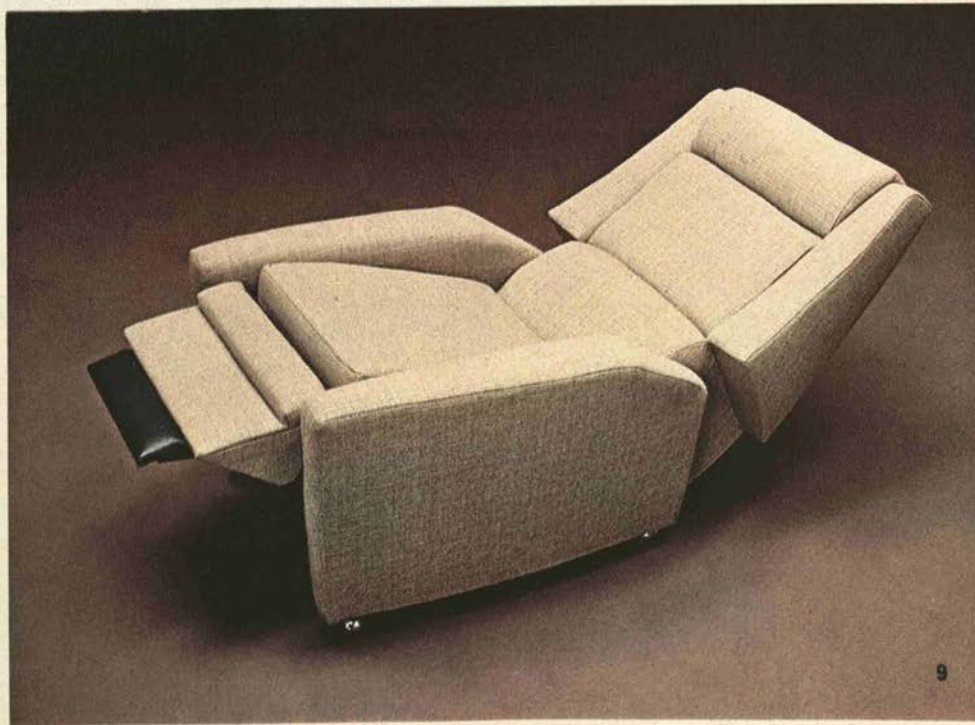



The Novara group.
The Novara recliner is happily
grouped with the
Novara chair (PK 1007) and
settee (PK 1008)
which give you the same
deep-down comfort.

The Florian group of ladderbacks -
PK 1017 low back chair, PK 1018 settee
and PK 1019 rocker. There is
a choice of button back and seat cushions,
or printed loose covers that
zip off for easy cleaning. The high backed
version of the chair is shown overleaf.



PK 1016 Florian high back



PK 751 Roslin



PK 752 Oban



PK 747 Newlyn



PK 945 Andante



PK 947 Adagio



PK 973 Ringwood

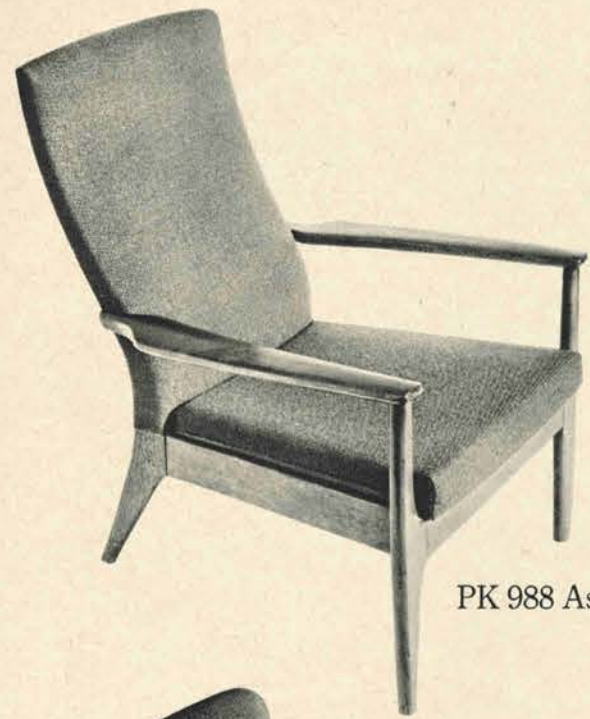

PK 988 Ashby

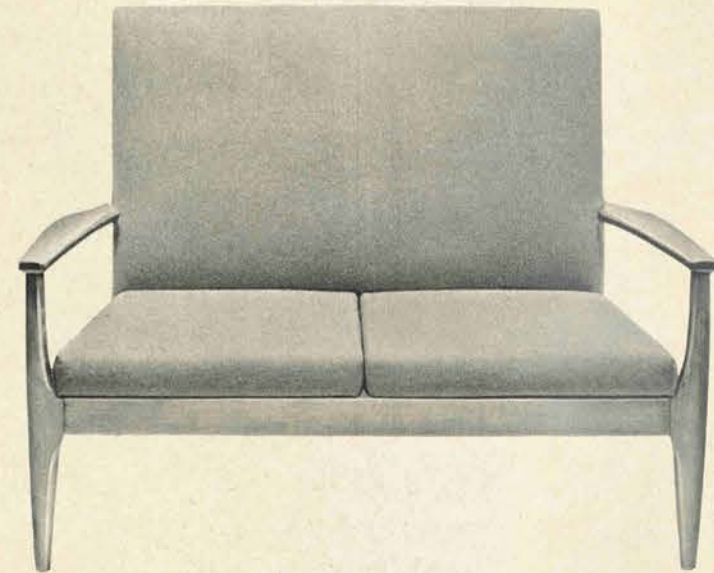

PK 997 Ashby Settee

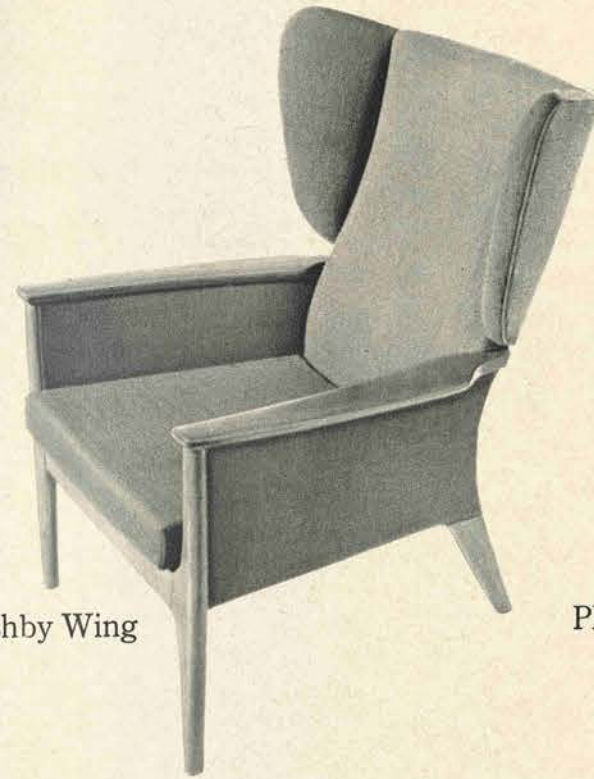

PK 991 Ashby Wing

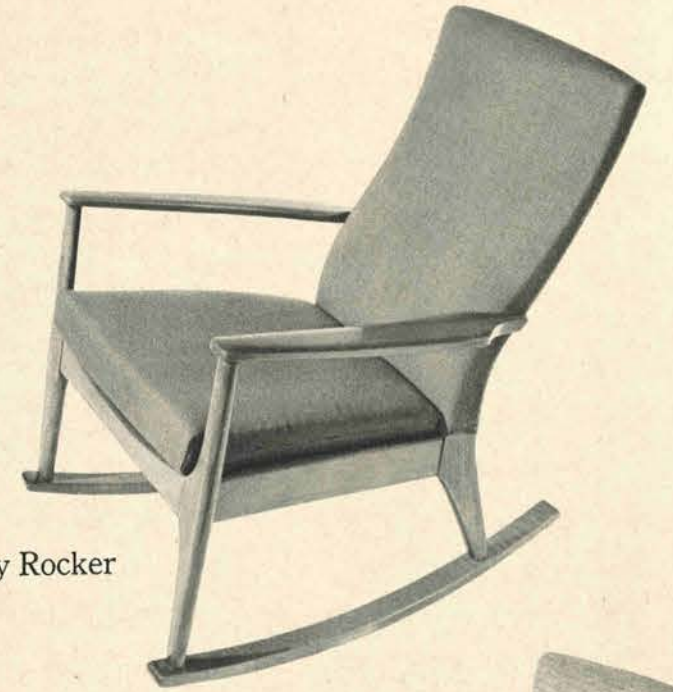

PK 989 Ashby Rocker



PK 992 Ashby Rockwing

The Ashby range covers a multitude of whims. Every model shown here, settee and rockers excepted, is available in a long-legged version. In addition, all give you a choice of Polyether cushions or, at small extra cost, Latex foam.

- PK 988 Ashby
- PK 989 Ashby Rocker
- PK 991 Ashby Wing
- PK 992 Ashby Rockwing
- PK 997 Ashby Settee
- PK 1023 Ashton

Long-legged chairs:

- PK 1024 High Ashby
- PK 1025 High Ashton
- PK 1026 High Ashby Wing



PK 1023 Ashton

PK 928 Highworth (left) and PK 929 Highwing (right).
 These considerate armchairs are specially designed to appeal to seniors. They offer good head and lumbar support enabling them to sit upright in perfect comfort and to get up without the aid of a helping hand. Seat height: 20 $\frac{3}{4}$ ". Both models are available with arm pads - PK 958 and PK 959.

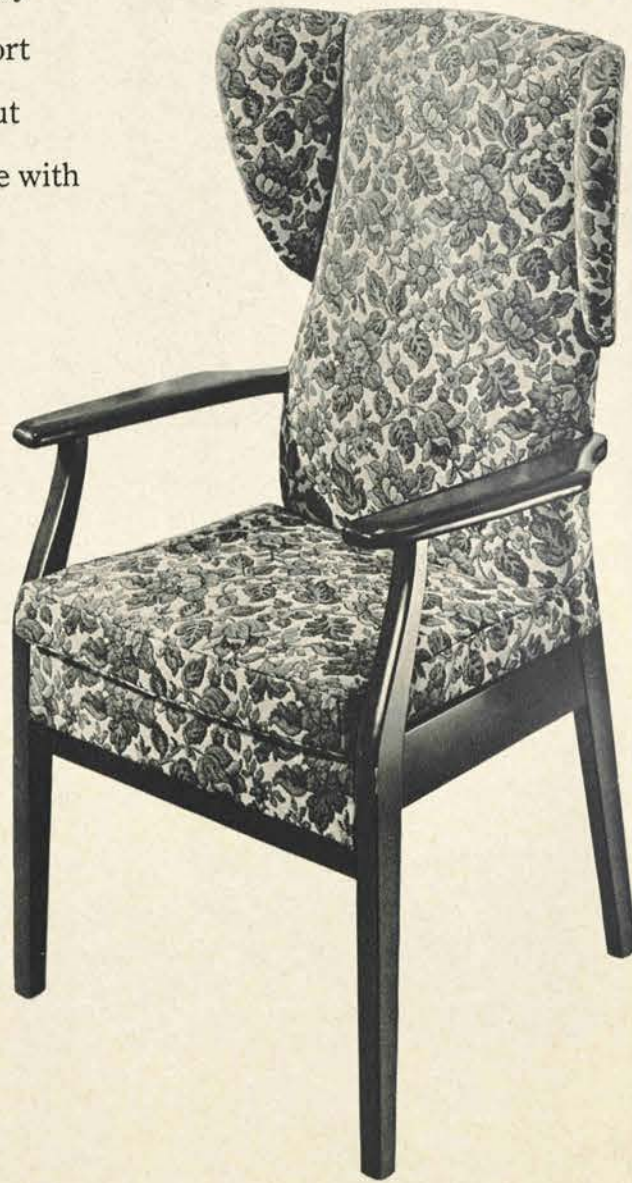

The Parker Collection.

Our founder, Frederick Parker, believed that the study of the 'old masters' was a sound basis on which to encourage good design and craftsmanship.

So when he started the business in 1870, he began to collect examples of the finest 17th and 18th century chairs and settees.

From these, his workmen acquired the skill and feeling of the early craftsmen and, in so doing, were inspired to create fine goods for contemporary use.

Today the same principle still applies.

And the collection has grown to be probably one of the finest of its kind in the country.

Part of the collection (it is too large to display in its entirety) is on view at Temple End. Designers, craftsmen, salesmen, in fact all who are interested in historical furniture, are invited to visit it by appointment any weekday between 9 am and 5 pm, Saturday excepted.



About 1765:
 Very rare mahogany and yew Windsor armchair of fine proportions. The curved centre splat, seat, and legs being of mahogany, the arms and spindles of yew.



About 1690:
 Interesting William and Mary walnut 'X' frame armchair, cane back.

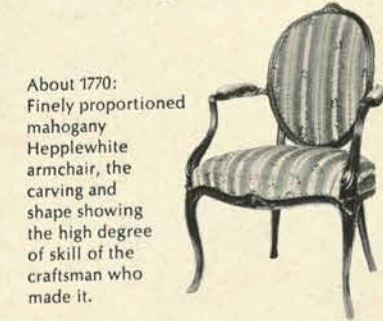

About 1770:
 Finely proportioned mahogany Hepplewhite armchair, the carving and shape showing the high degree of skill of the craftsman who made it.

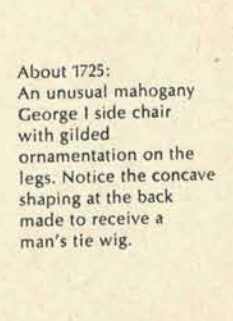

About 1725:
 An unusual mahogany George I side chair with gilded ornamentation on the legs. Notice the concave shaping at the back made to receive a man's tie wig.



About 1790:
 Fine example of a painted Sheraton side chair with circular seat.



About 1720:
 Very fine mahogany George I barber's chair, the splay terminating in a periwinkle scroll and with bold arms.

PARKER-KNOLL LIMITED

Sales Office

The Courtyard, Frogmoor, High Wycombe, Bucks. Telephone: High Wycombe 21144

Showrooms (Cornwell-Norton and Dancer and Hearne models also on display)

LONDON—19-20, Berners Street, W1P 3DD
 MANCHESTER—33, King Street
 BRISTOL—35, Park Street BS1 5NH
 HIGH WYCOMBE—The Courtyard, Frogmoor, Bucks.

Subsidiary Companies

PARKER-KNOLL TEXTILES LTD.

Sales Office & Warehouse:

Parkertex House, West End Road
 High Wycombe, Bucks.
 Tel: High Wycombe 22301

Showrooms

Parkertex House, 28, Berners Street,
 London, W1P 4JA

G. P. & J. BAKER LTD.

West End Road, High Wycombe, Bucks.

Showrooms

Parkertex House, 28, Berners Street,
 London, W1P 4JA

DANCER & HEARNE LTD.

The Courtyard, Frogmoor, High Wycombe,
 Bucks. Telephone: High Wycombe 33027

PK FURNISHINGS LTD.

Temple End, High Wycombe, Bucks.

FREDERICK PARKER & SONS LTD.

Temple End, High Wycombe, Bucks.

PARKER TEXTILES LTD.

West End Road, High Wycombe, Bucks.

CORNWELL-NORTON LTD.

23, Frogmoor, High Wycombe, Bucks.
 Telephone: High Wycombe 24326

LICENSEES

Australia

J. W. Parker (Furniture) Pty Ltd.
 Bellona Avenue, Regents Park,
 New South Wales.

Ghana

C.F.C. Furniture Co. (West Africa) Ltd.,
 P.O. Box 282, Ring Road, Accra.

Hong Kong

Lane Crawford Ltd, P.O. Box 83, Hong Kong.

India

Spencer & Co. Ltd., Mount Road, Madras.

Nigeria

C.F.C. Furniture Co. (West Africa) Ltd.,
 P.O. Box 42, Mushin, Lagos.
 C.F.C. Furniture Co. (Eastern Nigeria) Ltd.,
 P.O. Box 181, Port Harcourt.

Republic of South Africa

Associated Furniture Companies Ltd.,
 P.O. Box 10290, Johannesburg.

Rhodesia

Springmaster Corporation Ltd.,
 P.O. Box 800, Salisbury.
Branch Factory Bulawayo.

Sierra Leone

C.F.C. Furniture Co. (West Africa) Ltd.,
 P.O. Box 501, 27, Garrison Street, Freetown.

Singapore

Robinson & Co. Ltd., P.O. Box 828,
 Raffles Place, Singapore.

Zambia

Springmaster (Zambia) (Pvt) Ltd.,
 P.O. Box 552, N'dola.

Our interest in Parker-Knoll chairs and settees is never lost when we sell them. We know how attached people get to 'old favourites'. When we are asked if we can rejuvenate or re-cover a Parker-Knoll—no matter how many years of faithful service it has given—the answer is always 'yes' and the result is usually 'as good as new'.

A genuine Parker-Knoll can be identified by a name tape along the frame beneath the cushion seat or, in the case of fixed seat models, a name stamp on the underside of the frame.

Parker-Knoll Textiles

There is a wide choice of coverings for every style of Parker-Knoll chair. Some of these fabrics are original in design, others have been inspired by old documents, prints and needleworks in the Parker-Knoll Collection. Additional lengths can be bought for curtains, cushions or covers for the rest of your furniture. There are prices to suit all pockets, but we strongly recommend you to consider the better grades when making your choice.



NORWICH: Design adapted from an early 18th Century French Altar Cloth in our Collection.



RHODES: A simple textured tapestry woven in twelve colours.

HERE IS THE STANDARD RANGE OF WOOD FINISHES



Also White painted finish



Parker-Knoll

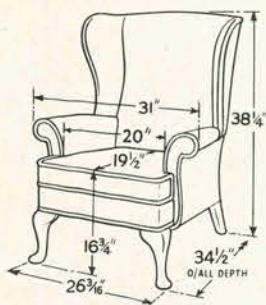

PK 720 Penshurst

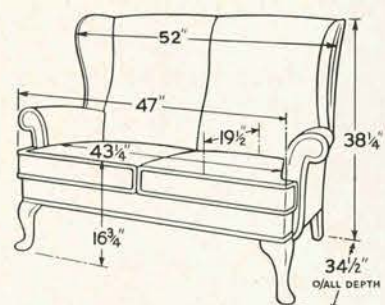

PK 745 Hawkhurst Settee. 2-seater.

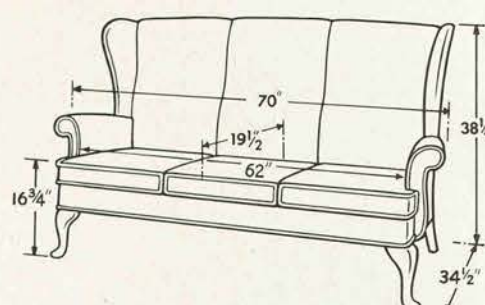

PK 1013 Hawkhurst Settee. 3-seater.

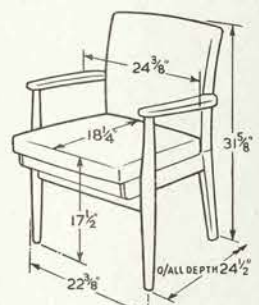

PK 733 Langford

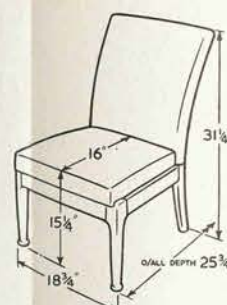

PK 747 Newlyn

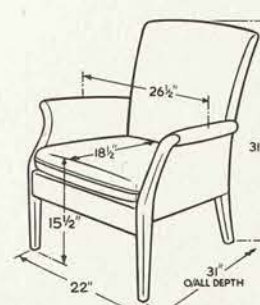

PK 749 Froxfield

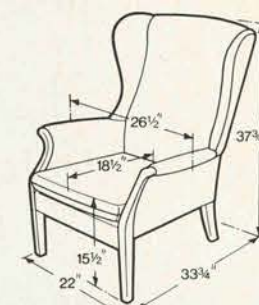

PK 750 Frith

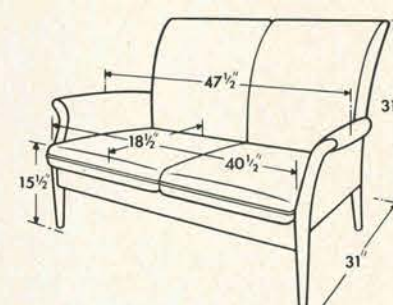

PK 1014 Froxfield Settee

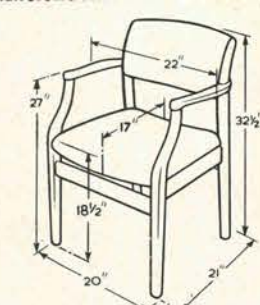

PK 751 Roslin

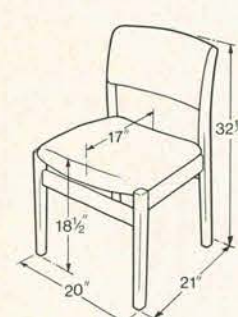

PK 752 Oban

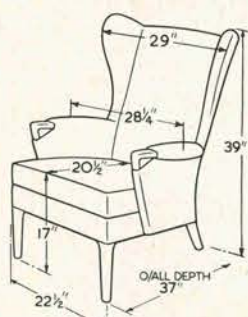

PK 757 Wingfield



PK 928 Highworth. Also PK 958

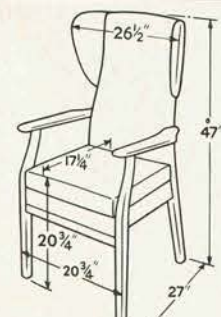

PK 929 Highwing. Also PK 959



PK 945 Andante

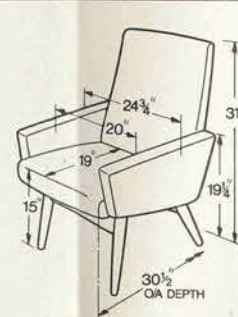

PK 947 Adagio

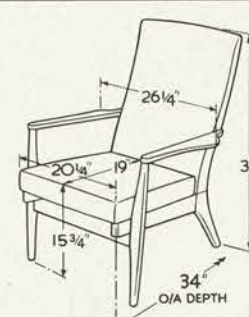

PK 973 Ringwood

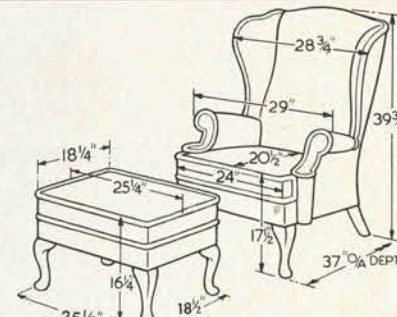

PK 976 Bosworth Chair
PK 977 Bosworth Stool

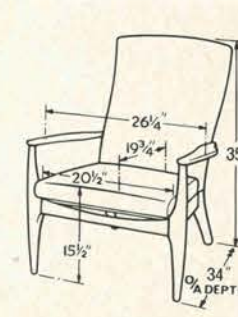

PK 988 Ashby

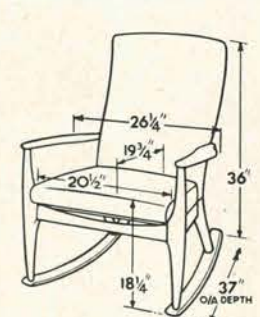

PK 989 Ashby Rocker

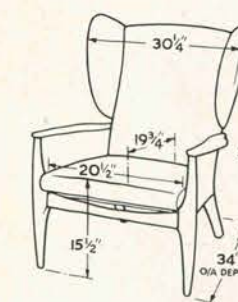

PK 991 Ashby Wing

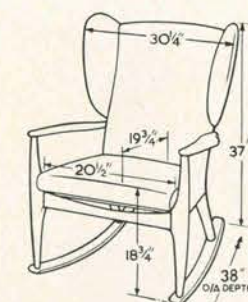

PK 992 Ashby Rockwing

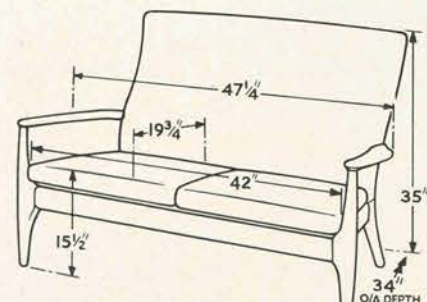

PK 997 Ashby Settee

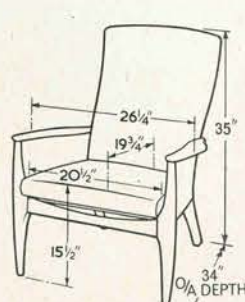

PK 1023 Ashton



PK 1024 High Ashby

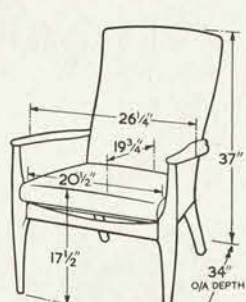

PK 1025 High Ashton



PK 1026 High Ashby Wing

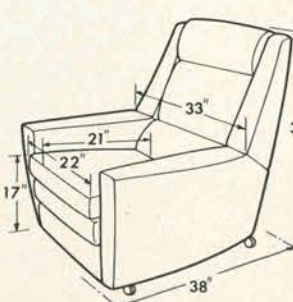

PK 1006 Novara Recliner - Upright

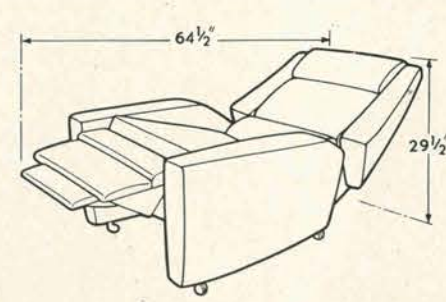

- Full recline

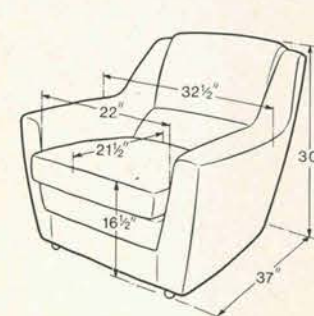

PK 1007 Novara Chair

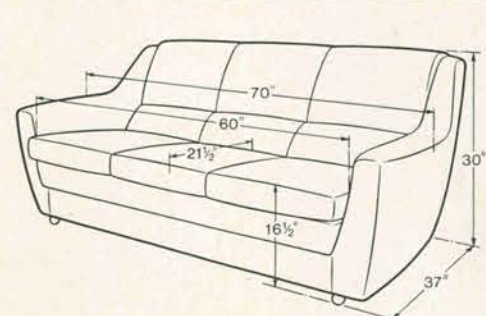

PK 1008 Novara Settee



PK 1016 Florian - Highback

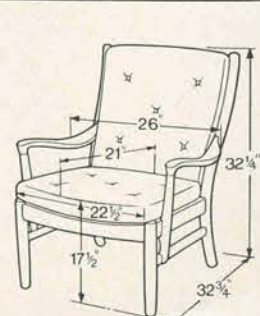

PK 1017 Florian - Lowback

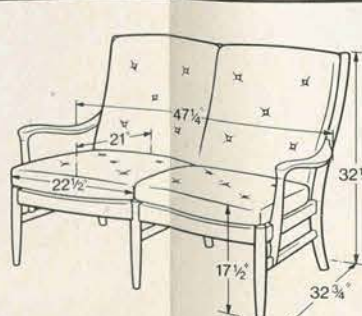

PK 1018 Florian Settee



PK 1019 Florian Rocker

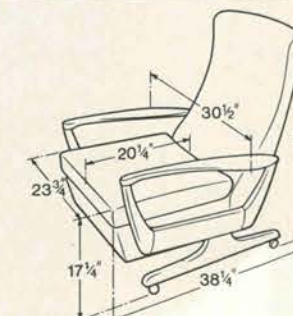

PK 1020 Strone Recliner - Upright

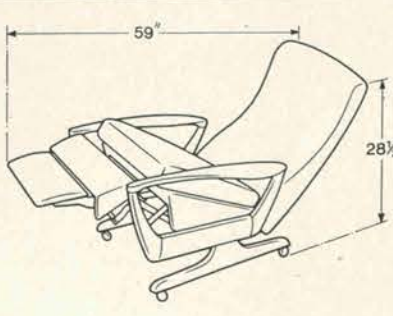

- Full recline

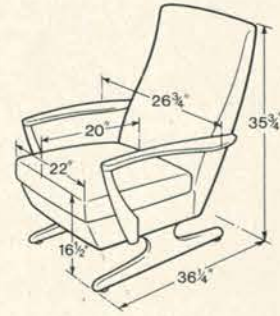

PK 1021 Stratton Rocker

Model	Name	Covers												Yardage		Own soft cover price					
		Cover "B"			Covers "A" or "R"			Covers "S" or "H"			"P" or "G" (Incl. Expanded Vinyl)			"V"		31"	50"	£	s. d.		
		£	s.	d.	£	s.	d.	£	s.	d.	£	s.	d.	£	s.	d.			£	s.	d.
P.K.720	Penshurst	—	—	—	46	5	0	49	15	0	54	5	0	68	5	0	8	4 $\frac{1}{2}$	45	5	0
P.K.733	Langford	—	—	—	17	0	0	18	0	0	19	0	0	22	15	0	2 $\frac{1}{2}$	1 $\frac{1}{2}$	16	10	0
P.K.745	Hawkhurst	—	—	—	87	10	0	93	15	0	101	10	0	125	0	0	12	6 $\frac{1}{2}$	86	0	0
P.K.747	Newlyn	—	—	—	16	5	0	17	5	0	18	10	0	22	15	0	2 $\frac{1}{2}$	1 $\frac{1}{2}$	15	15	0
P.K.749	Froxfield	—	—	—	30	10	0	33	10	0	36	5	0	45	0	0	5	2 $\frac{3}{4}$	29	5	0
P.K.750	Frith	—	—	—	37	15	0	40	15	0	44	5	0	55	5	0	7	3 $\frac{1}{2}$	34	0	0
P.K.751	Roslin	—	—	—	17	15	0	18	10	0	19	5	0	22	0	0	1 $\frac{3}{4}$	$\frac{3}{4}$	17	0	0
P.K.752	Oban	—	—	—	16	0	0	16	15	0	17	10	0	20	5	0	1 $\frac{3}{4}$	$\frac{3}{4}$	15	10	0
P.K.757	Wingfield	—	—	—	43	15	0	47	10	0	51	10	0	64	10	0	7 $\frac{1}{2}$	4 $\frac{1}{4}$	42	0	0
P.K.928	Highworth	27	0	0	29	5	0	31	0	0	33	15	0	40	15	0	4	2	26	10	0
P.K.929	Highwing	32	5	0	35	0	0	37	10	0	40	10	0	50	0	0	5 $\frac{1}{2}$	2 $\frac{1}{4}$	31	0	0
**P.K.945	Andante	21	10	0	23	5	0	24	15	0	26	15	0	32	5	0	3 $\frac{1}{2}$	1 $\frac{1}{2}$	19	10	0
P.K.947	Adagio	—	—	—	34	10	0	37	10	0	40	10	0	49	10	0	4 $\frac{1}{2}$	2 $\frac{3}{4}$	33	15	0
P.K.958	Highworth with arm pads	29	15	0	32	5	0	34	15	0	37	10	0	45	15	0	4 $\frac{3}{4}$	2 $\frac{1}{2}$	29	0	0
P.K.959	Highwing with arm pads	34	10	0	38	5	0	41	0	0	44	5	0	55	0	0	6	3	33	15	0
**P.K.973	Ringwood	19	15	0	21	10	0	23	5	0	25	5	0	31	5	0	3 $\frac{1}{4}$	2	17	10	0
P.K.976	Bosworth	—	—	—	54	5	0	59	10	0	63	0	0	78	0	0	8 $\frac{1}{2}$	4 $\frac{1}{2}$	53	0	0
P.K.977	Bosworth stool	—	—	—	25	5	0	26	10	0	28	0	0	33	0	0	2 $\frac{3}{4}$	1 $\frac{1}{2}$	24	10	0
**P.K.988	Ashby	18	10	0	20	5	0	21	10	0	23	5	0	28	5	0	3 $\frac{1}{2}$	1 $\frac{1}{4}$	15	15	0
**P.K.989	Ashby rocker	20	5	0	22	0	0	23	5	0	24	15	0	30	0	0	3 $\frac{1}{2}$	1 $\frac{1}{4}$	17	10	0
**P.K.991	Ashby Wing	27	10	0	30	5	0	32	15	0	35	15	0	45	10	0	6	3 $\frac{1}{4}$	22	10	0
**P.K.992	Ashby Rockwing	29	0	0	32	0	0	34	10	0	37	10	0	47	5	0	6	3 $\frac{1}{4}$	24	5	0
**P.K.997	Ashby settee	36	15	0	40	0	0	43	0	0	46	10	0	57	5	0	6 $\frac{1}{2}$	3 $\frac{1}{2}$	33	5	0
P.K.1006	Novara Recliner	—	—	—	85	0	0	93	5	0	100	15	0	123	15	0	—	7 $\frac{3}{4}$	83	0	0
P.K.1007	Novara chair	—	—	—	67	0	0	71	10	0	76	0	0	94	5	0	—	5 $\frac{1}{2}$	65	15	0
P.K.1008	Novara settee	—	—	—	134	10	0	143	5	0	151	15	0	186	10	0	—	10	132	10	0
P.K.1013	Hawkhurst 3-seater settee	—	—	—	106	0	0	114	5	0	124	0	0	155	0	0	17 $\frac{1}{2}$	9	103	0	0
P.K.1014	Froxfield settee	—	—	—	60	5	0	64	10	0	69	10	0	85	5	0	9	4 $\frac{3}{4}$	58	0	0
+P.K.1016	Florian	34	0	0	36	0	0	38	0	0	40	5	0	47	5	0	4 $\frac{1}{2}$	2 $\frac{1}{2}$	33	10	0
+P.K.1017	Florian lowback	32	0	0	34	0	0	36	0	0	37	15	0	44	0	0	4	2 $\frac{1}{2}$	31	10	0
+P.K.1018	Florian settee	55	0	0	61	0	0	64	10	0	68	10	0	80	10	0	8 $\frac{1}{2}$	4 $\frac{1}{2}$	54	10	0
+P.K.1019	Florian rocker	35	0	0	38	5	0	40	0	0	42	5	0	49	0	0	4 $\frac{1}{2}$	2 $\frac{1}{2}$	34	10	0
P.K.1020	Strone Recliner	—	—	—	58	5	0	60	15	0	64	0	0	74	0	0	—	3 $\frac{1}{4}$	57	10	0
P.K.1021	Stratton	—	—	—	37	15	0	40	10	0	43	15	0	53	0	0	—	2 $\frac{1}{2}$	36	10	0
P.K.1022	Waverley chair	—	—	—	48	10	0	51	10	0	55	0	0	66	0	0	—	3 $\frac{1}{2}$	47	10	0
**P.K.1023	Ashton	22	5	0	24	0	0	25	10	0	27	15	0	35	0	0	—	2 $\frac{3}{4}$	20	0	0
**P.K.1024	High Ashby	19	0	0	20	10	0	22	0	0	23	10	0	29	5	0	—	2	17	10	0
**P.K.1025	High Ashton	22	15	0	24	15	0	27	5	0	29	5	0	37	15	0	—	2 $\frac{3}{4}$	20	10	0
**P.K.1026	High Ashby Wing	27	15	0	30	10	0	33	5	0	35	15	0	46	15	0	—	3 $\frac{1}{8}$	24	15	0
P.K.1027	Waverley settee	—	—	—	83	0	0	88	0	0	94	0	0	113	0	0	—	5 $\frac{3}{8}$	81	10	0

IMPORTANT
P.K.720, P.K.745, P.K.1013, P.K.976, P.K.977.

These models normally supplied self-piped. When ruche and braid are ordered specially with "A", "S", "P" and own covers an extra charge will be made.

Prices omitted where covers are unsuitable.

Add proportionate quantity if your material is less than 50" or 31" wide.

There will be an extra charge for using own hide or own leather cloths.

*Alternatives to standard "V" panel make-ups require special quotations from your stockist.

†A range of prints is available on these four models at "B" price. Removable for cleaning.

Parker-Knoll Ltd., reserve the right to alter prices and specifications without notice.

Prices shown are those recommended August 1969.

**SPECIAL "O" PRICES FOR:—

P.K.945	.. 19	10	0	P.K.991	.. 22	15	0	P.K.1024	.. 17	5	0
P.K.973	.. 17	15	0	P.K.992	.. 24	10	0	P.K.1025	.. 20	5	0
P.K.988	.. 16	0	0	P.K.997	.. 33	10	0	P.K.1026	.. 24	10	0
P.K.989	.. 17	15	0	P.K.1023	.. 19	15	0				